

Modeling and analysis: power injection model approach for high performance of electrical distribution networks

Baraa Jalil Abdulelah¹, Yousif Ismail Mohammed Al-Mashhadany², Sameer Algburi³, Gozde Ulutagay⁴

^{1,4}Department of Industrial Engineering, Gedik University, Turkey

²Department of Electrical Engineering, College of Engineering, University of Anabr, Iraq

³College of Engineering Technology, Al-Kitab University, Iraq

Article Info

Article history:

Received Jul 2, 2021

Revised Sep 5, 2021

Accepted Oct 12, 2021

Keywords:

Electrical distribution networks

Grid power injection

Intelligent controller

Mathematical model

Renewable energies

ABSTRACT

The generation of electrical energy varies depending on the needs of the user, initial requirements, capacity, intended use, waste generation, and economic efficiency. In order to meet the challenges of the proposed overvoltage of the presented system, it is possible to use the solar collectors and profit from them economically through smart grid smart control systems. The mathematical model with four main parts was created: simulation, correlation, and evaluation according to the solar program set of photovoltaic solar modules, maximum power point tracking (MPPT), an adaptive neuro-fuzzy inference system (ANFIS) controller, and 600-volt electric network. Then in this phase, the investigation of the effects on the network on the basis of the output power with the coincidence of radiation and the effect of temperature in the network is carried out. An analysis was carried out to evaluate the impact of these fundamental limitations in practical application. In this section, the simulation of the proposed system is discussed. The block diagram of the developed system is presented in the last part. The proposed system was assessed from the Matlab simulation tapes and graphs for each part of the system, and the results of the overall system simulation were taken into account.

This is an open access article under the [CC BY-SA](https://creativecommons.org/licenses/by-sa/4.0/) license.



Corresponding Author:

Yousif Ismail Mohammed Al-Mashhadany

Department of Electrical Engineering

University of Anabr, Anbar, Iraq

Email: yousif.mohammed@uoanbar.edu.iq

1. INTRODUCTION

The conveyance part of the electrical power framework is the part answerable for conveying electrical vitality to end-clients in the wake of changing over them from high voltage to electrical voltage. The lines having a place with this part are the medium voltage circuit. The dissemination framework, as a rule, comprises various substations that comprise transformers that set up the voltage planning to the suitable level for clients, which exit from the substation. Close to every client an end, that is, it very well may be summed up by saying: The sub-circulation station gets an elevated level voltage and performs ventures down and conveys to the helper circuit of the low voltage. Vitality quality is one of the materials generally influenced by the presentation of photovoltaic (PV) cells into dispersion systems. Symphonious flows will be produced because of the utilization of intensity transformers when PV is applied to control matrices. Therefore, it will expand the complete consonant mutilation related to the flows and voltage in the contact territory. Be that as it may, the sounds of the voltage are typically inside cutoff points if the network is adequately perfect with less chain obstruction. Then again, the current sounds produce a current that may not be sinusoidal. The state of the twisting rush of this current can be convoluted by the kind of burden and its treatment of different pieces of the framework. This chapter presents the fundamental concepts for grid power

injection through electrical distribution networks, literature review for three main parts of this subject, problem statement, and objective from this work [1]-[3].

The power grid is a series of transformers and infrastructure that transmit electricity from the production center to all consumers. These power grids are responsible for transmitting and distributing the electricity generated by the power source to the end of the electricity consumption. For centuries, the distance between the main production center and the end-user has been long. In terms of the characteristics of consumers and renewable energy companies, the physical network is being modernized to make it more convenient. The grid seems to be considering the ability to provide smart control. This chapter introduces the latest of these new grid structures, called smart grids. A new power grid concept is emerging, which can intelligently integrate the actions and measures of all relevant parties to ensure a safe, economical, and sustainable power supply. There are many types of energy sources, and they are directly connected to the transmission network. There are also some small distributed renewable resources, such as PV solar modules, energy storage, small wind farms, which should be placed near the consumption points in the low-voltage power distribution network to meet the efficiency and economic requirements. Therefore, the development of small networks may be a way to solve these problems. Now, new electronic energy technologies and digital control systems can create small, advanced networks that operate independently of the network and can incorporate multiple distributed energy sources. Presents a fine grid overview, showing the concept of positioning and the advantages and disadvantages of AC and DC allocation [4], [5].

2. RESEARCH METHOD

2.1. PV grid topology

In grid-connected PV networks, a significant thought in transformer plan and activity is the manner by which to accomplish high effectiveness with the power yield of different power setups. Inverter association necessities include most extreme power point, high proficiency, control power infused into the organization, and low all-out harmonic distortion of the flows infused into the system. Along these lines, the presentation of the network-associated transformer depends generally on the control methodology applied. Power inverter topologies and control structures for grid-associated PV frameworks. The various arrangements of grid-associated PV networks and power inverter geographies are portrayed as demonstrated in Figure 1. A few arrangements are proposed to control the infused power into the organization and the useful designs of every setup [6].

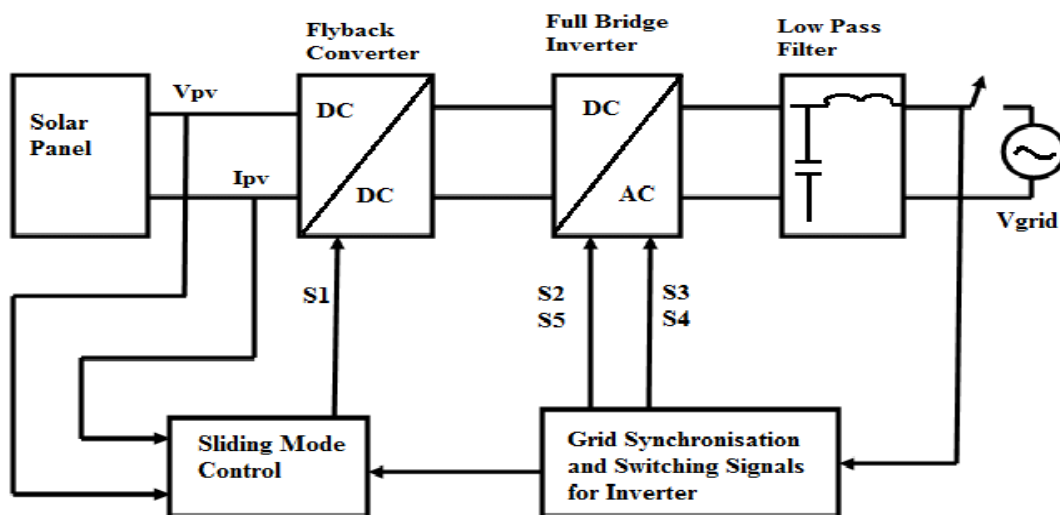

Figure 1. Proposed grid-connected PV inverter system based on SMC and flyback converter topology

2.2. PV grid generation model

There are difficulties in coordinating the PV power generation into the power system. An appropriate model for the PV power generation is crucial for concentrate on how photoelectric control incorporates and connects with these power system defiances. The PV power generation models needed for power network researches can be delegated dynamic and stable models. The model ought to appropriately address the different highlights of the PV power age like geography, control structure; and so on this talks about the

particular engineering of a PV power generation, its segment displaying, and the subtleties of the control calculation. Advancement of the proper powerful model for energy network considers. The model was utilized for the situation study to test the effect of power generation of PV on the little sign solidness of the power system. The consistent state models needed to contemplate the operational difficulties of a power scheme, for example, consistent state voltage control [7], [8].

2.3. Grid system features

There is another power network framework, which can possibly satisfy the present requests in an exceptionally sufficient manner. This power lattice is known as the keen framework. Savvy matrix incorporates an extremely proficient thought which is dynamic distribution systems. The circulation network which has countless dissemination generations like PV, WT, power device, and capacity framework is called dynamic dispersion organizations [9]. This appropriated generation will make the lattice network a two-way dissemination network, which implies that we can give dynamic and receptive capacity to the matrix networks and take the dynamic and responsive power from the lattice network. In spite of the fact that having circulated energy assets in our dissemination network has had numerous advantages for our framework [10]. For instance, getting better energy quality, lessening framework energy misfortune, and invigorating the energy market. This DER will help the DSO in the zones of power quality, voltage appraisals, and overloaded feeders. MG can work comparable to the framework or autonomously when a blackout happens, and MG can supply electrical capacity to the town, production line, or local location and features topology for grid system as shown in Figure 2 [11].

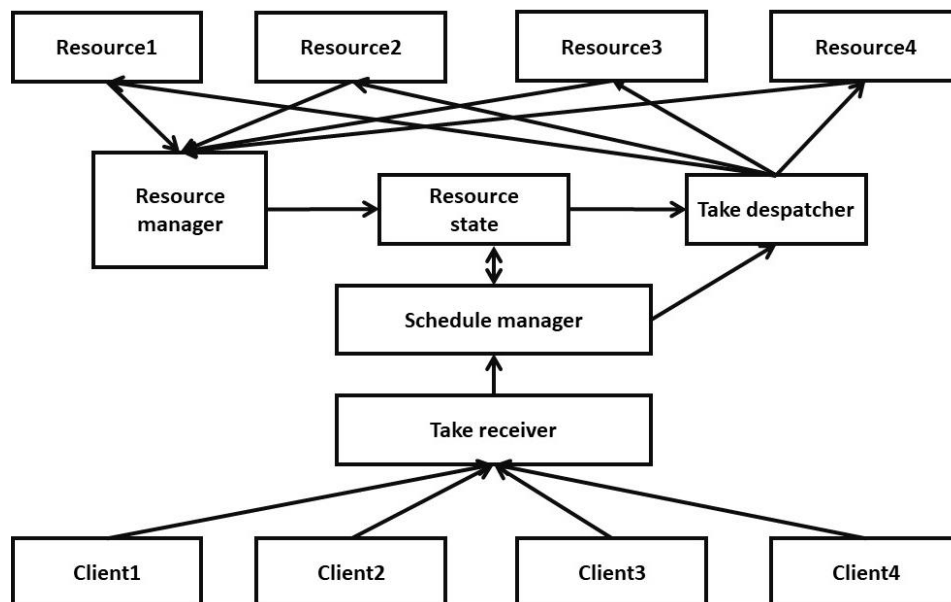

Figure 2. Proposed grid system features topology [11]

Moreover, MG can be exceptionally valuable for DSO to use as reinforcement power and helper appropriated framework administrator at top burden time, which implies greatest power required and valley point time, which implies least force required, this will build network proficiency [12]. In a dissemination network when we experience voltage brutality out of the blue, we attempt to make up for it by adding more capacitors to our framework through the capacitor bank, through this cycle, we increment the receptive power in the network. The circulation of energy assets in our network likewise builds the dynamic force in our framework which we can use to diminish the general misfortunes of the network [13]. The presence of sustainable power in our framework implies that in our framework we utilize the variety of energizes to create our force, which likewise goodly affects the climate. One of the elements that caused the old network framework to endure is load change, which implies voltage variance, yet by coordinating DG into our framework we can make up for this issue. Organizations administrators expect expanded investment of the PV age in network uphold tasks. This is because of the hazardous development of PV producing units. The normal organization upholds highlights of PV age have been portrayed in certain guidelines. These can be partitioned into two fundamental classes, which are dynamic organization uphold highlights and consistent state network uphold highlights [14].

2.3.1. Dynamic grid parameters

This class of highlights incorporates the administrations that PV generation gives during network aggravation occasions. The principal administrations expected in different organization codes are low voltage ride, issue responsive current infusion, and frequency uphold as shown in Figure 3.

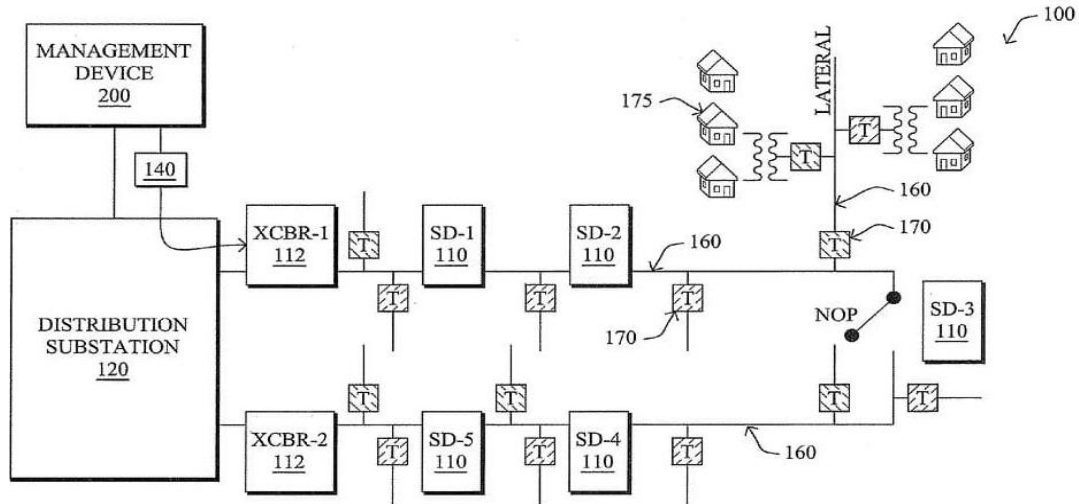

Figure 3. The dynamic configuration of the parameters of the distribution feed in an electrical network [15]

2.3.2. Dynamic voltage parameters

The more seasoned variant of the matrix tokens was required to detach the PV terminals from the framework during the voltage drop. This can prompt generation misfortune on account of enormous PV combination situations [16]. The low voltage ride across (LVRT) predicts that the PV power infusion will proceed for a brief timeframe to maintain a strategic distance from the irritating stumbling of the PV plant. This evades huge PV infusion misfortunes, accordingly staying away from additional framework breakdown. The LVRT of the MV network is appeared in Figure 4 for instance [17].

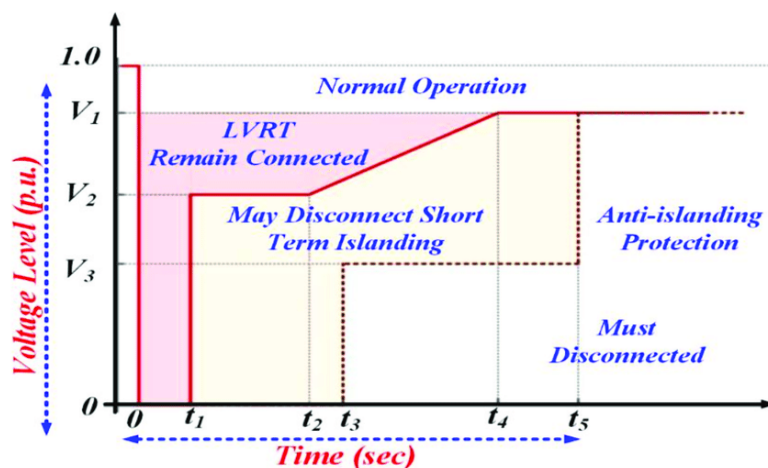

Figure 4. Low voltage ride-through (LVRT) requirements of the connected time under abnormal conditions and anti-islanding protection

3. MATHEMATICAL MODEL OF INTELLIGENT VOLTAGE CONTROL SYSTEM

3.1. DC/DC boost converter

The PV unit deemed in this search gives yield voltage esteems not exactly the specific organization needed for DC [18]. In this way, the voltage level should be expanded and the transformer should work in

help mode. The schematic chart shows the lift transformer with a left-to-right power stream, the fundamental parts being the inductor L, the capacitor C in the output, the switch IGBT, and the diode used in the circuit, and the load R [19]-[22]. Figure 5 explain the principle signs of a boost converter. PWM is the sign for the control stage, the voltage and the current in the inductance compare to the force stage [23]. Figure 6 explain the signals at boost converter, the period for time on and time off for converter operation is very clear in this figure.

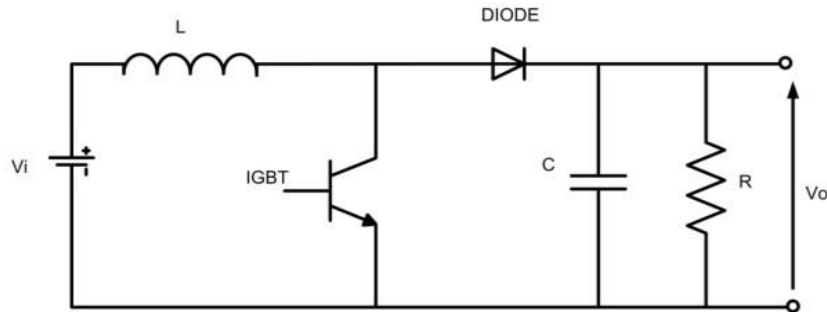

Figure 5. The circuit at boost converter [22]

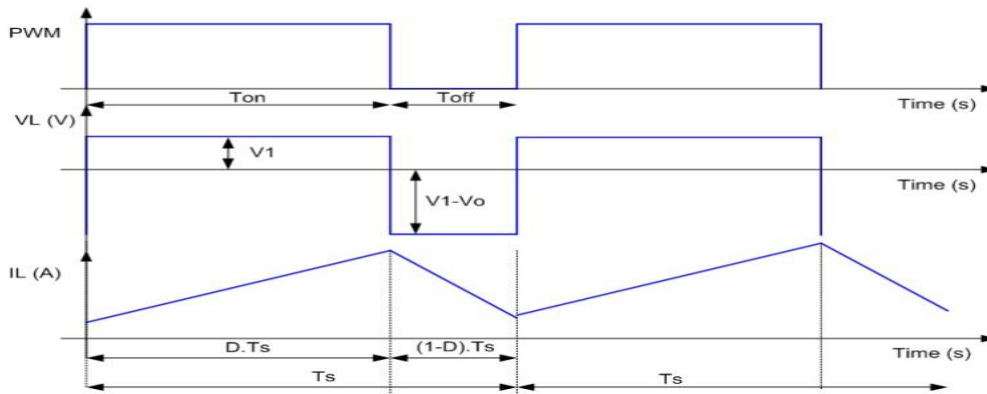

Figure 6. The signals at boost converter [23]

It is feasible to track down a total numerical examination of the lift transformer, consequently, in this segment; just the most significant equations are introduced.

$$v_c = \frac{1}{c} \int_{t_2}^{t_1} i_c dt \tag{1}$$

It is determined on the grounds that the connection between and current through the inductor is:

$$i_L = \frac{1}{L} \int_{t_2}^{t_1} v_L dt \tag{2}$$

Where v_L is equal to v_1 during T_{on} and $v_L = v_1 - v_0$ during T_{off}
 The connection between voltage shifts in the CCM of the lift transformer is:

$$v_0 = v_i \frac{1}{1-D} \tag{3}$$

Given the mean qualities, the connection amidst the inductor current and yield current, continually action in the CCM of the lift transformer is:

$$i_L = i_0 \frac{1}{1-D} \tag{4}$$

So amidst the external and the current internal, the relationship will be [23]-[26]:

$$i_0 = i_1 1 - D \quad (5)$$

3.2. Structure of intelligent voltage control system

Solar energy is quite possibly the main sustainable power source and has acquired expanding consideration as of late. Solar-based energy is plentifully contrasted with other fuel sources. The radiation of the sun tumbling to the earth in a solitary day is adequate to supply the absolute energy of the world's energy needs for one year. Solar energy is perfect and outflow-free as it doesn't create poisons or destructive side effects of nature. Changing over solar energy into electrical energy has numerous application territories. Private, vehicle, space, airplane, and marine applications are the primary solar energy spaces. A PV cell converts sunlight into electricity (power), the actual cycle recognized as the photoelectric impact. The light, which PV cell beams are likely to be reflected, assimilated, or went complete; however, just consumed light creates power. The energy of the consumed light is moved to the electrons in the molecules of the PV cell as shown in Figure 7. On account of their newfound energy, these electrons run away from their common areas in the bits of the semiconducting PV material and become part of the electrical motion, or flow, of an electrical circuit. An exceptional electrical feature of a photoelectric cell called a "built-in electrical domain," provides sufficient power or voltage to lead flow via an outer "load" such as a light bulb [26]-[32].

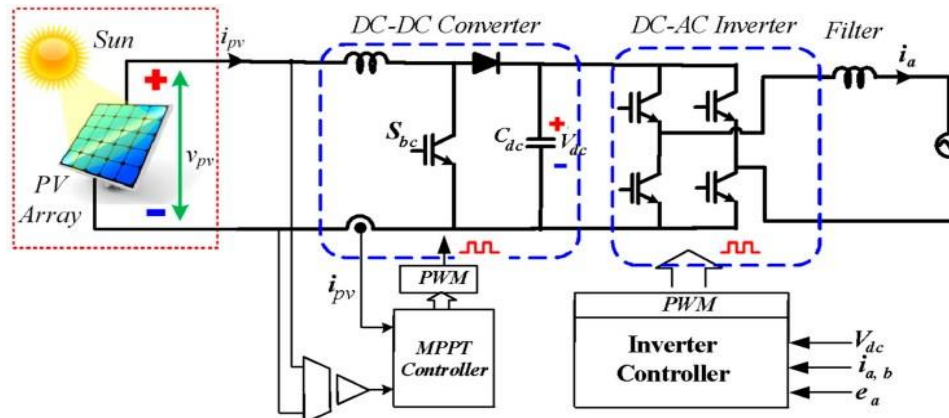

Figure 7. PV grid-connected system [31]

In a lattice-associated inverter, in the output stage, DC intersection voltage control and current control are completed. The ordinary lift transformer control unit is controlled to follow up the voltage source sign (v_{pv} *) created by the MPPT calculation. The switch is constrained by an entryway sign of the current regulator.

4. SIMULATION RESULTS, ANALYSIS AND DISCUSSION

The overabundance sun based PV energy can be put away in the battery and used to oblige the night load which can be named self-utilization or, as per the proposed system, it is feasible to infuse the abundance energy into the distribution network from the excess force of the private homes that utilization sunlight based boards and advantage from it economically by Intelligent control systems for smart grid.

The simulation of the proposed system will be discussed in this section. The block diagram of the developed system is displayed in Figure 8. The input light for the system is converted to electrical power inside this system. This power can be used to feed the main electricity grid with 600V of power. In addition to the capability of using the power immediately to any load can be added to the system. The evaluation of the proposed system got from the scopes and graphs of Matlab simulation of each part of the system. Also, the simulation results of the aggregate system were considered.

Figure 9, shows the parameters and curves of the system within 10s time period. The curves of the output power and irradiance are showed a high stability and perfect output. Also, the scopes gave a statistics of power, since the max power of MPPT was $2.7 * 10^4$. When the min power was $7.4 * 10^1$ and the median was $7.6 * 10^3$.

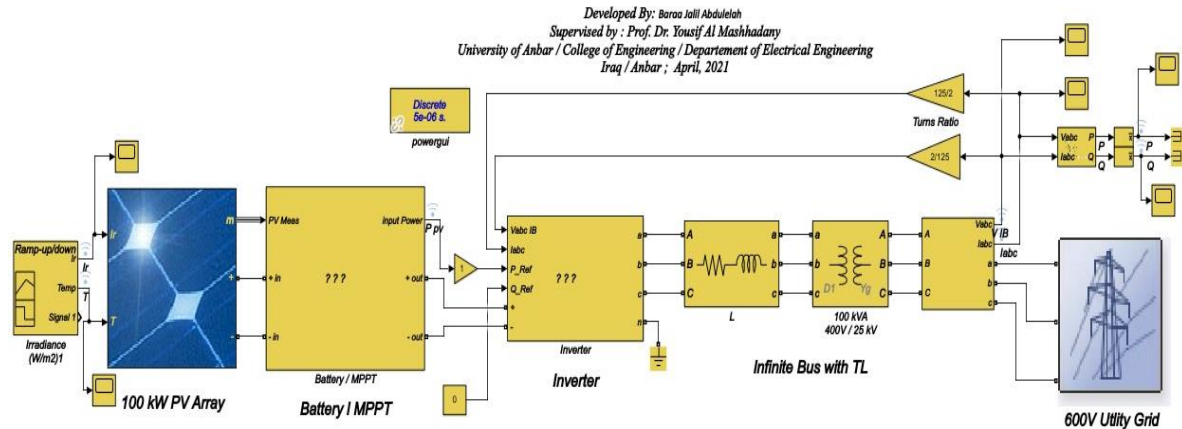

Figure 8. The overall block diagram of system design

The injected active power (P) and reactive power (Q) to the grid is shown in Figure 9. The output of DC-AC simulation is shown in this figure. The measured time period is 10s in the figure we can see stability in the output action power near of $1 \times 10^5 W$ at action power. In another hand, the reaction power is continuing to be near of zero.

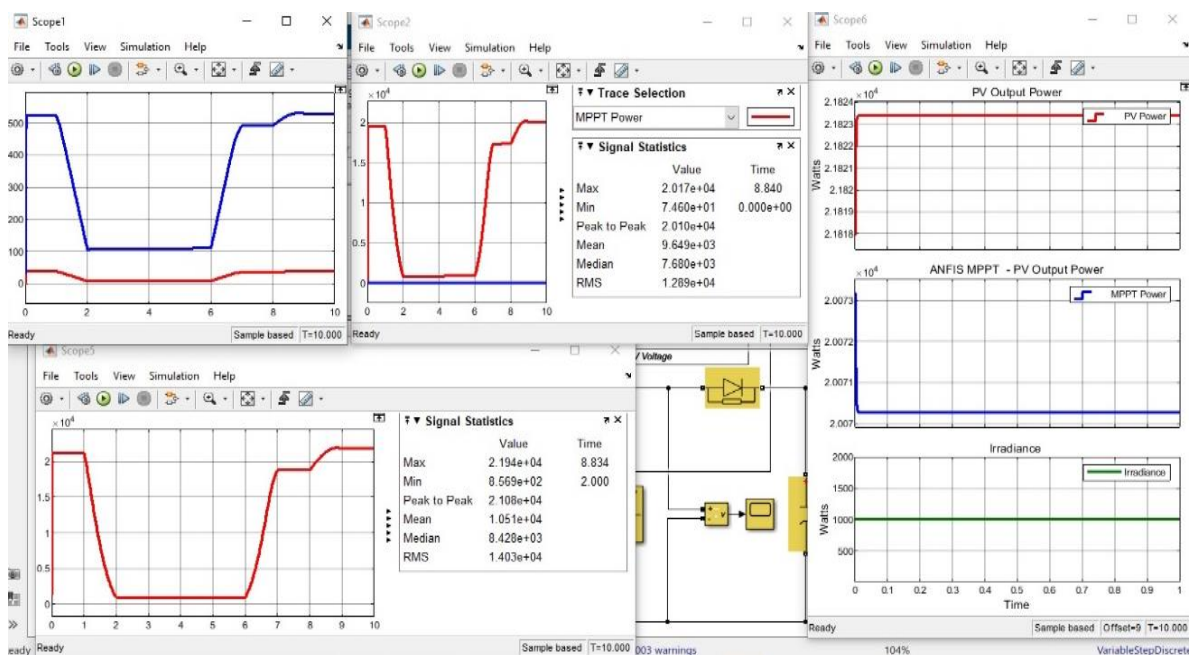

Figure 9. The overall simulation of intelligent voltage control for injection power system

Figure 10 shows the overall simulation of applied intelligent controller with grid power system. The actual PV power distribution feed is modeled as a simulation of the entire system. Simulations show that the proposed strategy for reactive power coordination is effective to minimize the number of taps, prevent mismanagement and keep the feed voltage within specified limits. Consider the night reactive power support from PV inverters. It has been shown that when the active output power of the PV system is zero, the bypass operation can be minimized by using the reactive power capability of the PV inverter. Strategies when there are PV generators. The proposed strategy is considered to be beneficial to distribution system operators. With the help of strategies, various voltage regulator settings can be developed and the control of PV generators can be configured in the daily operation of the distribution network.

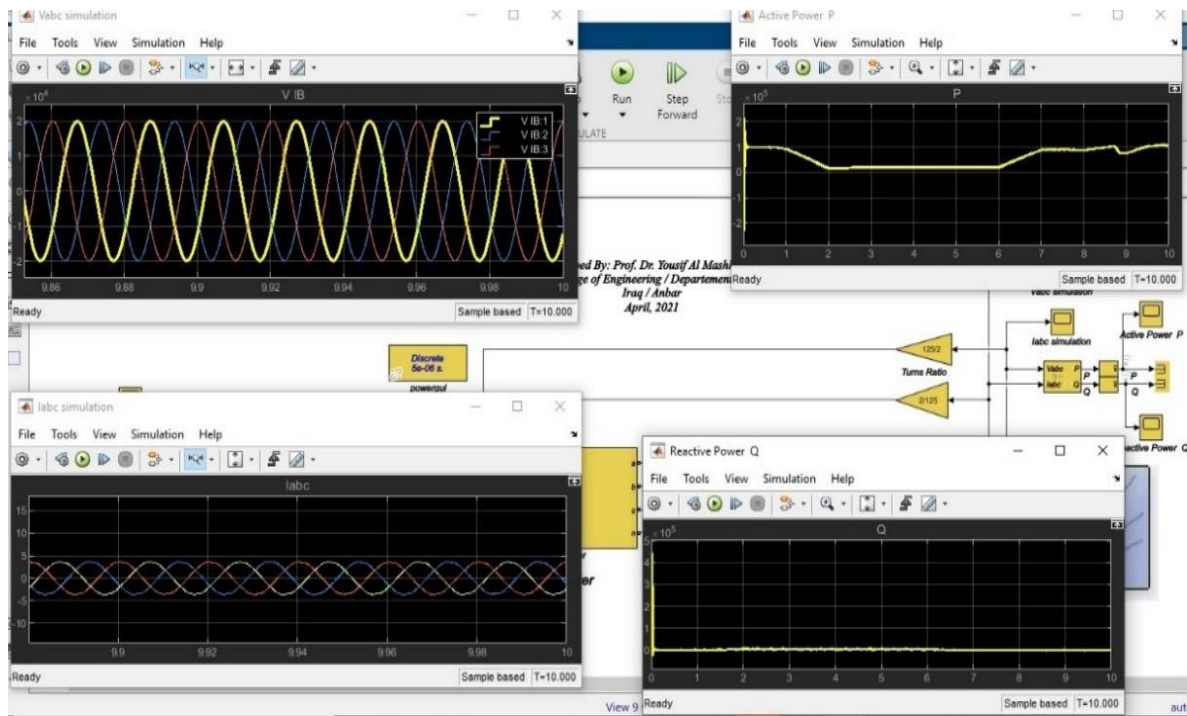

Figure 10. The overall simulation of applied intelligent controller with grid power system

5. CONCLUSION

The main objective of this proposed system is to configure the power flow from the small power grid to the main electrical networks by using the radiation of renewable energy influenced by temperature. This process is carried out by an integrated system of electrical control devices, which consists of main parts, a solar energy filter, a dc-dc boost voltage converter system, a voltage inverter and ANFAS logical control, and a 600 utility grid. In this proposed system, each of these parts has been detailed, in addition to making simulations through the Matlab program and analyzing the results to obtain the stability of the voltage and the reactive power of the system.

We can take advantage of the voltage and reactive power generated from the system to feed personal homes and share the main energy sources with reactive energy by injecting the surplus generated energy into the main distribution networks, and our proposed system will be of great economic feasibility instead of wasting energy at sufficiency hours and exporting the benefit to the national electricity. After compiling a mathematical model vocabulary for all parts of the feeding system in the main network, and simulating all parts of it, displaying the output signal, and identifying the changes in its elements

ACKNOWLEDGEMENTS

We would like to thank the Department of Industrial Engineering, Gedik University for supporting me to complete this work.

REFERENCES

- [1] B. Hu, J. Yang, J. Li, S. Li, and H. Bai, "Intelligent control strategy for transient response of a variable geometry turbocharger system based on deep reinforcement learning," *Processes*, vol. 7, no. 601, pp. 1-17, 2019 doi: 10.3390/pr7090601.
- [2] J. Nowakova and M. Pokorny, "Intelligent controller design by the artificial intelligence methods," *Sensors*, vol. 20, no. 20, pp. 1-27, 2020, doi: 10.3390/s20164454.
- [3] R. Pal, and S. Gupta, "Topologies and Control Strategies Implicated in Dynamic Voltage Restorer for Power Quality Improvement," *Iranian Journal of Science and Technology, Transactions of Electrical Engineering*, vol. 44, no. 2, pp. 581-603, 2020.
- [4] A. Y. Adnan, H. M. Abdul, and M. K. Iwan, "Intelligent control for ship manoeuvring," *Journal of Advanced Research in Applied Mechanics*, vol. 67, no. 1, pp. 1-9, 2020, doi: 10.37934/aram.67.1.19.

- [5] M. S. Haghghi, F. Farivar, A. Jolfaei, and M. H. Tadayon, "Intelligent robust control for cyber-physical systems of rotary gantry type under denial of service attack," *The Journal of Supercomputing*, vol. 76, no. 4, pp. 3063-3085, 2020.
- [6] C. Mugnier, K. Christakou, J. Jatou, M. De Vivo, M. Carpita and M. Paolone, "Model-less/measurement-based computation of voltage sensitivities in unbalanced electrical distribution networks," *Power Systems Computation Conference PSCC*, 2016, pp. 1-7, doi: 10.1109/PSCC.2016.7540852.
- [7] P. Li, H. Ji, G. Song, C. Wang, and J. Wu, "Self-healing oriented supply restoration method based on the coordination of multiple SOPs in active distribution networks," *Energy*, vol. 195, no. 116968, 2020, doi: 10.1016/j.energy.2020.116968.
- [8] R. Kabiri, D. G. Holmes, B. P. McGrath and L. G. Meegahapola, "LV Grid Voltage Regulation Using Transformer Electronic Tap Changing, With PV Inverter Reactive Power Injection," *IEEE Journal of Emerging and Selected Topics in Power Electronics*, vol. 3, no. 4, pp. 1182-1192, 2015, doi: 10.1109/JESTPE.2015.2443839.
- [9] S. Huang, Q. Wu, S. S. Oren, R. Li and Z. Liu, "Distribution Locational Marginal Pricing Through Quadratic Programming for Congestion Management in Distribution Networks," *IEEE Transactions on Power Systems*, vol. 30, no. 4, pp. 2170-2178, 2015, doi: 10.1109/TPWRS.2014.2359977.
- [10] Q. Qi, J. Wu, L. Zhang and M. Cheng, "Multi-objective optimization of electrical distribution network operation considering reconfiguration and soft open points," *Energy Procedia*, vol. 103, pp. 141-146, 2016, doi: 10.1016/j.egypro.2016.11.263.
- [11] K. E. A. Plytaria, I. N. K. Lysikatos, P. S. Georgilakis and N. D. Hatziaargyriou, "Distributed and Decentralized Voltage Control of Smart Distribution Networks: Models, Methods, and Future Research," *IEEE Transactions on Smart Grid*, vol. 8, no. 6, pp. 2999-3008, 2017, doi: 10.1109/TSG.2017.2679238.
- [12] A. Bonfiglio, F. Delfino, M. Invernizzi, and R. Procopio, "A Methodological Approach to Assess the Impact of Smarting Action on Electricity Transmission and Distribution Networks Related to Europe 2020 Targets," *Energies*, vol. 10, no. 2, pp. 1-17, 2017.
- [13] A. H. Abed, J. Rahebi and A. Farzamia, "Improvement for power quality by using dynamic voltage restorer in electrical distribution networks," *IEEE 2nd International Conference on Automatic Control and Intelligent Systems (I2CACIS)*, 2017, pp. 122-127, doi: 10.1109/I2CACIS.2017.8239044.
- [14] C. Wag, G. Song, P. Li, H. Ji, J. Zhao and J. Wu, "Optimal siting and sizing of soft open points in active electrical distribution networks," *Applied energy*, vol. 189, pp. 301-309, 2017, doi: 10.1016/j.apenergy.2016.12.075.
- [15] Y. He, G. J. Mendis and J. Wei, "Real-Time Detection of False Data Injection Attacks in Smart Grid: A Deep Learning-Based Intelligent Mechanism," *IEEE Transactions on Smart Grid*, vol. 8, no. 5, pp. 2505-2516, 2017, doi: 10.1109/TSG.2017.2703842.
- [16] S. Wang, K. Yang and K. Chen, "An Improved Position-Sensorless Control Method at Low Speed for PMSM Based on High-Frequency Signal Injection into a Rotating Reference Frame," *IEEE Access*, vol. 7, pp. 86510-86521, 2019, doi: 10.1109/ACCESS.2019.2925214.
- [17] L. Yu, X. Sun and T. Sui, "False-Data Injection Attack in Electricity Generation System Subject to Actuator Saturation: Analysis and Design," *IEEE Transactions on Systems, Man, and Cybernetics: Systems*, vol. 49, no. 8, pp. 1712-1719, Aug. 2019, doi: 10.1109/TSMC.2019.2915527.
- [18] Z. Liu, J. Liu and Z. Liu, "Analysis, Design, and Implementation of Impulse-Injection-Based Online Grid Impedance Identification With Grid-Tied Converters," *IEEE Transactions on Power Electronics*, vol. 35, no. 12, pp. 12959-12976, Dec. 2020, doi: 10.1109/TPEL.2020.2995016.
- [19] G. Celli, F. Pilo, G. G. Soma, M. Gallanti and R. Cicoria, "Active distribution network cost/benefit analysis with multi-objective programming," *CIREN 2009 - 20th International Conference and Exhibition on Electricity Distribution - Part 1*, 2009, pp. 1-5, doi: 10.1049/cp.2009.1031.
- [20] G. Li, G. Li, C. Zhao and H. Liang, "Research on Voltage Source Converter Based DC Distribution Network," *2nd IEEE Conference on Industrial Electronics and Applications*, 2007, pp. 1927-1932, doi: 10.1109/ICIEA.2007.4318746.
- [21] M. Sadeghi and S. A. Asghari, "Recommender Systems Based on evolutionary computing: a survey," *Journal of Software Engineering and Applications*, vol. 10, no. 5, pp. 407-421, 2017, doi: 10.4236/jsea.2017.105023.
- [22] Y. I. Al-Mashhadany, "Modeling and simulation of Adaptive Neuro-Fuzzy controller for Chopper-Fed DC Motor Drive," *IEEE Applied Power Electronics Colloquium IAPEC*, 2011, pp. 110-115, doi: 10.1109/IAPEC.2011.5779859.
- [23] Y. I. Al-Mashhadany, "Inverse Kinematics Problem (IKP) of 6-DOF Manipulator by Locally Recurrent Neural Networks (LRNNs)," *International Conference on Management and Service Science*, 2010, pp. 1-5, doi: 10.1109/ICMSS.2010.5577613.
- [24] Z. He, J. Zhang, W. Li and X. Lin, "Improved Fault-Location System for Railway Distribution System Using Superimposed Signal," *IEEE Transactions on Power Delivery*, vol. 25, no. 3, pp. 1899-1911, 2010, doi: 10.1109/TPWRD.2010.2041372.
- [25] E. Manitsas, R. Singh, B. C. Pal and G. Strbac, "Distribution System State Estimation Using an Artificial Neural Network Approach for Pseudo Measurement Modeling," *IEEE Transactions on Power Systems*, vol. 27, no. 4, pp. 1888-1896, Nov. 2012, doi: 10.1109/TPWRS.2012.2187804.
- [26] P. S. Georgilakis and N. D. Hatziaargyriou, "Optimal Distributed Generation Placement in Power Distribution Networks: Models, Methods, and Future Research," *IEEE Transactions on Power Systems*, vol. 28, no. 3, pp. 3420-3428, Aug. 2013, doi: 10.1109/TPWRS.2012.2237043.
- [27] J. N. Sheen, M. T. Tsai and S. W. Wu, "A benefits analysis for wind turbine allocation in a power distribution system," *Energy conversion & management*, vol. 68, pp. 305-312, 2013, doi: 10.1016/j.enconman.2012.12.022.

- [28] S. Repo *et al.*, "Active distribution network concept for distributed management of low voltage network," *IEEE PES ISGT Europe*, 2013, pp. 1-5, doi: 10.1109/ISGTEurope.2013.6695428.
- [29] Z. Liu, Q. Wu, S. S. Oren, S. Huang, R. Li and L. Cheng, "Distribution Locational Marginal Pricing for Optimal Electric Vehicle Charging Through Chance Constrained Mixed-Integer Programming," *IEEE Transactions on Smart Grid*, vol. 9, no. 2, pp. 644-654, 2018, doi: 10.1109/TSG.2016.2559579.
- [30] M. Manbachi, H. Farhangi, A. Palizban, and S. Arzanpour, "A novel volt-VAR optimization engine for smart distribution networks utilizing vehicle to grid dispatch," *International Journal of Electrical Power & Energy Systems*, vol. 74, pp. 238-251, 2016, doi: 10.1016/j.ijepes.2015.07.030.
- [31] V. Ilea *et al.*, "Voltage Control Methodologies in Active Distribution Networks," *Energies*, vol. 13, no. 12, pp. 1-33, 2020, doi: 10.3390/en13123293.
- [32] Y. I. A. Mashhadany, "ANFIS-inverse-controlled PUMA 560 workspace robot with spherical wrist," *Procedia Engineering*, vol. 41, pp. 700-709, 2012, doi: 10.1016/j.proeng.2012.07.232.

BIOGRAPHIES OF AUTHORS



Baraa Jalil Abdulelah is employer in electrical Anbar office. He received the B.Sc. (2009) from Department of Electrical Engineering, College of Engineering, and University of Anbar. He applies M.Sc. study with Istanbul Gedik University now.



Prof. Dr. Yousif Ismail Mohammed Al-Mashhadany is a lecturer in Electrical Engineering Department – College of Engineering (Control Engineering). Senior member IEEE, He received the B.Sc. (1995), M.Sc. (1999), and Ph.D (2010) in University of Technology in Baghdad/Iraq. He complete postdoctoral fellow research in electrical engineering - control department at the University of Malaya in Malaysia (UMPEDAC) in 2012. He has many publishing that included three books, two chapters, Forty five Journals paper most of them (Clarivate, Scopus and international journal), and thirty nine conferences paper. He has 5 in H-index with Scopus, has 11 H-index with Google scholar, has 4 H-index in Publons with 126 reviews. Editor with Anbar Journal of Engineering Science.



Prof. Dr. Sameer Algburi was born in Kirkuk in 1959 PhD in electrical engineering Visiting professor at the Center for Middle Eastern Studies, Lund University, Sweden Founder and President of the Swedish Iraqi Studies Network, and Vice President of the International Friendship Organization in the Kingdom of Sweden Founder and Chairman of the Board of Trustees of the Knowledge Enrichment Academy in the International Friendship Organization Professor at Al Kitab University.



Prof. Dr. Gözde Ulutağay currently works at Istanbul Gedik University, Industrial Engineering Department. She received B.Sc. (2001) and M.Sc. (2004) degrees from Ege University, and Ph.D degree (2009) from Dokuz Eylül University in Izmir/Turkey. She was in University of Texas at El Paso, USA- Computer Science Department as Visiting Researcher in 2011. She has over 20 articles in journals and about 40 conference papers. Her H-index is 6 according to Web of Science, and 9 according to Google scholar. She has been serving as Editor for Applied Soft Computing for more than 6 years. Her main research interests include fuzzy clustering, data mining, artificial intelligence and multivariate statistics.