

A radio frequency identification based smart shopping trolley system for automated billing

Maham Kamil Naji¹, Alaa Desher Farhood², Hayder Fadhil Fahad², Adnan Hussein Ali¹

¹Department of Electronics Techniques Engineering, Institute of Technology, Middle Technical University, Baghdad, Iraq

²Department of Electronics Techniques Engineering, Technical Instructor Training Institute, Middle Technical University, Baghdad, Iraq

Article Info

Article history:

Received Jul 30, 2022

Revised Oct 15, 2022

Accepted Nov 27, 2022

Keywords:

Automated billing

Radio frequency identification

Radio frequency identification readers

Smart shopping system

Trolley system

ABSTRACT

On holidays and weekends, we can notice a large rush at shopping centres in metro areas. This is exacerbated when there are substantial discounts and deals. By applying the notion of internet of thing (IoT) for concerning all things in the grocery store, an automated smart shopping system is created. Each product within such scheme had an economical radio frequency identification (RFID) tag positioned with it. Once an item has been added to a smart cart, the information about the merchandise is quickly read by the RFID reader on the cart. The outcome is, direct invoicing is done out from shopping cart, saving clients from having to wait in a long line at the checkout. The product's expiration date is also displayed and broken products can be determined by their weight. As a result, expired and damaged products will not be taken into account when calculating the cost. Furthermore, this system gains the addition of smart shelves incorporating RFID readers which may check stock and possibly update a central server. Inventory control becomes simpler as a result. Finally, cashier stations could verify a customer's purchase. As a result, billing may be done right in the trolley, saving clients a lot of time.

This is an open access article under the [CC BY-SA](https://creativecommons.org/licenses/by-sa/4.0/) license.



Corresponding Author:

Alaa Desher Farhood

Department of Electronics Techniques Engineering, Technical Instructor Training Institute

Middle Technical University

Baghdad, Iraq

Email: alaa.desher@gmail.com

1. INTRODUCTION

Since the dawning of time, people have been inventing new ways to meet their requests. The need for more independency is the main force behind innovation, which leads to bettering tasks and making routine ones simpler and faster. Shopping is a crucial task in which people expend the greatest amount of energy. People travel to shopping centers to purchase items they need on a daily basis, including food, clothing, and electrical appliances [1]. Clients frequently express dissatisfaction with the lack of particular information regarding the marked-down item and the waste of unnecessary time at the counters. To help consumers choose and store the items they plan for purchasing, shopping trolleys are used at every grocery store and supermarket in today's innovative world. Typically, customers purchase everything they require, add it to their trolleys, and then stand in line to pay their bills at the registers [2], [3]. The method that bills are paid at the counters is pretty simple cumbersome and time-consuming, which causes a significant through there. Consumers spend an average of 1.4 hours each week shopping, depending on data from a US government organization [4], [5]. Substantial numbers of consumers will leave a line if it is excessively long. There are two categories in the present retail landscape: shopping in-individual and shopping in absentia.

Here, the shopping in absentia, like an internet shopping, web shopping, and so forth, is encouraged from a variety of perspectives since it reduces the need for the customer to be manually held at the counters.

Making a personal call to the store and choosing items based on several criteria including necessity, convenience, and quality is individualized shopping [6]. The suggested sharp shopping basket structure aims to assist in-person shopping and minimizing the amount of time consumed shopping. To improve the character of the shopping background for the clients, consistent alteration in the normal time spent at the counters is essential [7], [8]. We've put up a shopping basket to address the concerns mentioned above and to improve the current framework. This may be accomplished with simply relating radio frequency identification (RFID) labels for the things then a reader purchasing books with a LCD. Clients can obtain information about the cost of each item in their cart, as well as the absolute cost of the item, using this framework [9]. With regard to the cost of the item, this framework will reduce clients' time and the labour necessary in the shopping centre [10].

The aforementioned issues can now be resolved in a few different ways, but progress is still taken into account when evaluating performance. Using barcode scanning technology in the cash register, where the price is stored in the barcode, modern problem-solving techniques maybe fixed up a customer communication counter to assist the client if a goods inside the department store are a concern. This replaces the conventional method of manually keying in each item in the shopping mall one at a time. In order to suit client needs, mall technology must be upgraded often. The aforementioned problems could be improved upon or solved if RFID technology is ultimately used in shopping malls. As a result, this paper proposes a smart trolley using RFID as an effort to replace the current barcode technology. The structure of the paper is as follows: the suggested system is explained in section 2, the processing procedures at smart shopping trolley and RFID are outlined in section 3, section 4 is described the various outputs, and section 5 we outline some future study directions.

2. MATERIAL AND METHOD

2.1. System overview

The typical electronics system consists of two components: hardware and software. These can be designed at the same time to shorten the design cycle time. It also enables the hardware and software design teams to collaborate in order to resolve any incompatibility concerns that may develop throughout the design process [11]. Several hardware and software tools to accomplish this project's goal, which are listed:

2.1.1. Hardware required

It is essential to understand that depending on the implementation device, system limits, performance objectives, and the precise hardware requirements may change. Considerations like cost, power economy, and portability should be taken into account when choosing hardware components that can handle the processing requirements of the sleepiness detection system. The hardware required to achieve the objective are as: i) Arduino ATmega328, ii) Bluetooth module, iii) load cell, iv) LCD display (16×2), v) transistor, vi) diodes, vii) resistors, viii) capacitors, ix) RFID card, x) EM-18 RFID reader, xi) piezoelectric sensor, and xi) power supply.

2.2. Principle of operation

This system's major objective is to show how an innovative framework for buying products off the market may be designed and set up. This cart looks into new mobile innovations and programmed, established proven advances (like RFID) as to enhance the calibre of services offered by businesses, boost customer satisfaction, and save time and money [12]. Using this cart, you'll have a great opportunity to help customers by presenting a product catalogue and the prices connected with it. As a result, the account control system benefits from an automatic upgrade with each product transaction. Such smart cart had the ability for making customers' shopping more reliable, comfortable, and systematic while also making store management easier [13].

A smart shopping trolley system is created utilising a microcontroller and RFID tags in this project. The concept is to use several RFID tags. The RFID reader will read the product's values (price, expiration date, and weight) from the RFID tags connected to the product, and then send the data to the microcontroller [14]. The microcontroller will receive signals from the RFID reader and display them on the LCD, which is connected to the microcontroller, according to the programming. After making a final purchase, the customer will press a button that will send the bill to the central billing unit through Bluetooth module and microcontroller [15].

2.2.1. Block diagram of smart trolley

A smart trolley is a high-tech device created to improve the usefulness and effectiveness of conventional trolleys used in a variety of sectors, including retail, logistics, and storage. The main parts of the system and how they interact may be shown visually in the block diagram of a smart trolley. Figure 1 displays the suggested system's block diagram that contains the Arduino mega as a central unit with a connection of all parts needed for RFID scheme. It shows how information, signals, and control move between the various parts and emphasizing their functions and connections.

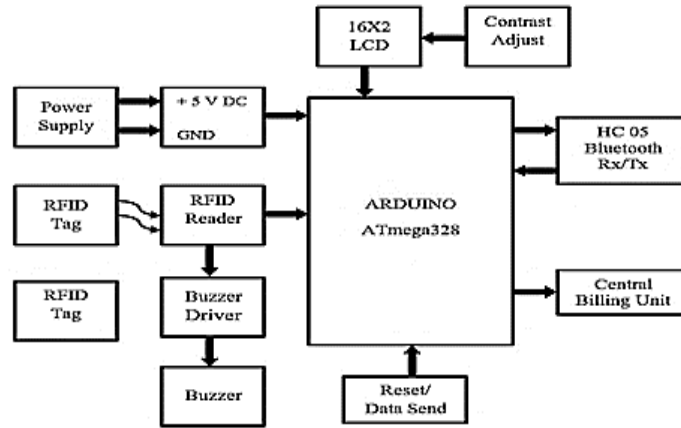

Figure 1. Block diagram of smart trolley

2.2.2. Schematic diagram

A representation diagram of smart trolley can be shown in Figure 2 and the Bluetooth to USB converter is shown in Figure 3. The connection of both Arduino mega is done through double pins 26 and 27. Also LCD is connected to Arduino by several pins as well as the Bluetooth unit.

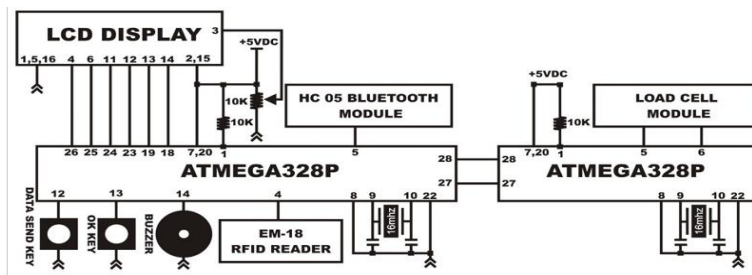

Figure 2. Schematic diagram of smart trolley

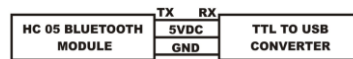

Figure 3. Bluetooth to USB converter

2.3. Circuit description

As we know that there are so many types of microcontroller families that are available in the market. In order to fulfill our application ATmega328 controller is enough [16]. While, there are many sensors that are being used in this project such as RFID tags, buzzer, Bluetooth module, and load cell. All sensors have some basic common features that are required in our circuitry including cheap and easily available in the market, accuracy is high, and all the sensors are operated at 5 V.

2.4. Components description

2.4.1. Microcontroller Atmega328

ATMEL Corporation, situated in the United States, is a semiconductor designer and manufacturer that was founded in 1984 [17]. The microchip 8 bit AVR RICS-centered microcontroller has 32 KB ISP flash memory thru read-while-write abilities, 1 KB electrically erasable programmable read only memory (EEPROM), 2 KB static random access memory (SRAM), 23 general intent I/O lines, 32 functioning registries for all purposes, 3 bendable timers/counters includes comparison modes, interruptions both internal and external, programmable serial universal synchronous/asynchronous receiver transmitter (USART), a byte concerned with two wire serial interfacing, and internal and external interrupts [18]. There are 28 pins on the

ATmega328. It features 14 digital I/O pins, including six pulse width modulation (PWM) output pins and six analogue input ports. Twenty of the pins are used for I/O.

2.4.2. HC-05 serial Bluetooth

A Bluetooth serial module is used for transforming a serial port into Bluetooth. These modules support the master and slaver device modes as shown in Figure 4. When a device with an even name leaves the factory, it is preconfigured to be either a master or a slave and cannot be switched to the other mode [19]. Using attention instructions, users can change the device's work mode (master or slaver) for devices designated after odd numbers [20]. The communication must be between master and slave, the password must be correct.

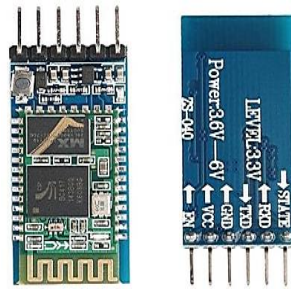

Figure 4. HC-05 Bluetooth module

2.4.3. Load cell

Force transducers include load cells. This transforms a force, which including tension, compression, pressure, and torque into a quantified and standardized electrical output. The electrical signal varies in direct proportion to the load cell's applied force. Hydraulic, pneumatic, and strain gauge load cells are the most commonly utilized as shown in Figures 5 and 6 for strain gauges [21].

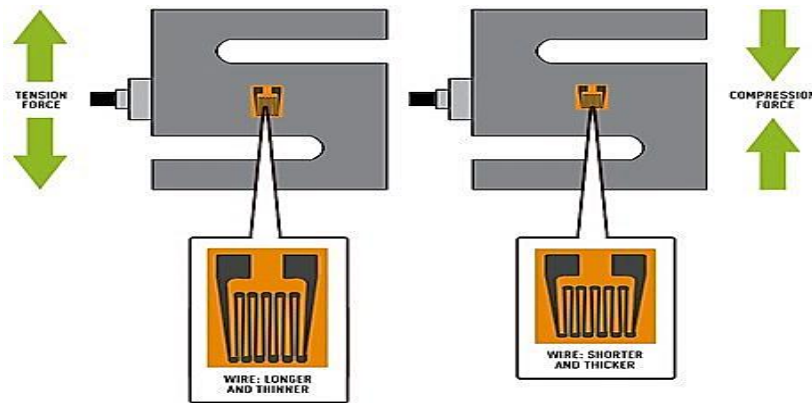

Figure 5. Strain gauge

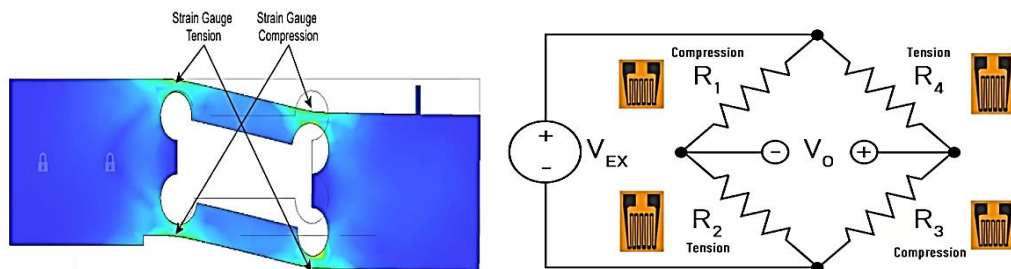

Figure 6. Strain gauge load cell

2.4.4. Liquid crystal display

A LCD be present an electronic display element that creates a graphic produced via liquid crystal. A 16×2 LCD display is an elementary module which may be originate in various DIY projects and circuits. The 16×2 is a display by way of 16 characters per line in two lines. Every character is shown in a 5×7 pixel matrix on this LCD. These modules are recommended over multi-segment LCDs with seven segments shown in Figure 7.

2.4.5. Transistor

The term transistor comes from the term "transfer resistors," which refers to a solid-state semiconductor device. As a result, a transistor is a semiconductor device that is employed in electronics to control amplitude. The collector, the base, and the emitter are the three terminals of a transistor (only after all of the leads are properly linked in the circuit will the transistor work). There are principally two transistor types and have different form as shown in Figure 8.

2.4.6. Capacitor

An electrical component called a capacitor has two terminals and can store potential energy within an electric field. The term "capacitance" is used to characterize a capacitor's effect. Originally, the capacitor was known as a condenser. Capacitance is proportional to the surface area of the plates (conductors) and inversely proportional to the spacing between them in a capacitor. In practice, a little amount of leakage current travels through the dielectric between the plates. It has a limit to the strength of its electric field, which is known as the breakdown voltage. Capacitors are normally utilized in electronic circuits for blocking DC whereas permitting AC for flowing through them. So, there are mainly four types of capacitor which are given.

2.4.7. Piezoelectric sensor

A piezoelectric element can be driven by an electronically oscillation circuit or another audio signal source, which is then amplified with piezoelectric audio amplifier as shown in Figure 9. Common noises used to indicate that a button has already been pushed include a click, ring, or beep. A piezoelectric buzzer or beeper employs Helmholtz resonance or acoustic cavity resonance to produce an audible beep [22].



Figure 7. LCD display

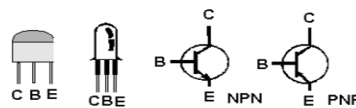

Figure 8. Transistors types and form



Figure 9. Piezoelectric buzzer

2.4.8. Power supply

The electron flow in alternating current is alternate, i.e. it climbs to a maximum in one direction and then declines to zero in the other direction. It subsequently increases in the other direction until dropping back to zero. Only one way current flows in a direct current. A rectifier is a device that converts alternating electricity into a single-direction flow. The diode is forward biased whenever the anode and cathode are in a positive relationship, allowing current to flow. It is reverse biased and does not allow current to flow when compared to the cathode, its anode is negative. The diode's unidirectional characteristic is advantageous for rectification.

3. RADIO FREQUENCY IDENTIFICATION

A wireless ID technology called RFID uses radio waves to identify the existence of RFID tags. Similar to bar code scanners, RFID technology is used to detect the presence of individuals, objects, and other things. To optically scan a barcode using barcode technology, it must be kept in front of the reader, however in RFID technology, it only necessity to fetch RFID tags within choice of scanners. Furthermore, barcodes might have scratched or unreadable, while most RFID devices do not [23]. It is utilised in a variety of applications, such as an appearance system, where each person has their own RFID tag that helps identify them and their attendance. Many companies utilise RFID to provide identification for their authorised personnel. By putting a tag (with a unique ID) on them, it is also possible to maintain track of goods and use an automatic toll collection system on the highway. Two fundamental components of a RFID-based system: RFID tag which consist of a microchip mounted on a substrate with a radio antenna and a 12 byte unique identification number (shown in Figure 10).

EM-18 RFID reader: it's used to read RFID tags' unique IDs. The RFID reader scans a RFID tag's unique ID when it comes within range of the reader, sending the information serially to the microcontroller or PC [24]. The RFID reader has an antenna and a transmitter. It is generally kept in a constant posture. It sends an exclusive ID consecutively to the PC or microcontroller by means of connecting UART or Wiegand format on the suitable pins once reading tags [25]. The EM-18 RFID reader does not require line-of-sight communication. It also has a small identification range, i.e. a few millimeters.



Figure 10. RFID tag inside

4. RESULTS AND DISCUSSION

For obtaining products, the smart shopping trolley system for automated billing with RFID was developed, which improves security and speed while shopping in shopping malls. The system contains many outputs which are as: when the cart is unloaded, as seen in Figure 11, the LCD displays "BIG BAZAAR FUTURE RETAIL" to signify that the trolley is empty. To begin, the shopper must add the item to their cart. The reader then scans the RFID tag placed within the goods when a customer places a product called "AMUL GHEE" in the trolley, it displays the product name, weight, expiration date, cost, and a beep sound created by the buzzer circuit to confirm that the product has been scanned by the trolley as seen in Figure 12. Until the product weight matched the scanned product using the load cell attached to the smart trolley, the buzzer made a beeping sound.

The product output that is added to the trolley is shown in Figure 13. It displays the overall weight as well as the total cost of the items in the trolley. The cost and weight of an item will not be changed if the product weight does not match. Finally, once a transaction is completed, the customer should push the send button causing the bill for the acquired objects to be transferred over Bluetooth terminal (Figure 14(a) and recorded in the database (Figure 14(b)) while the confirmation of the bill is shown in Figure 14(c).



Figure 11. The first LCD display



Figure 12. Output of a scanned product

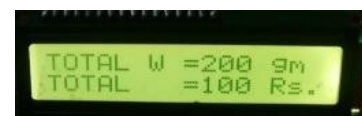

Figure 13. Good product output



(a)



(b)

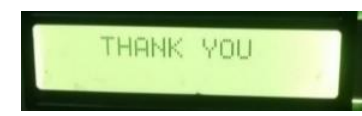

(c)

Figure 14. The output of the bill for all cases: (a) output of the bill generator, (b) output of the bill, and (c) bill confirm

The output that can be retrieved via an application is shown in Figure 15. The user must go to the counter of the store. As a result, the cost for the products purchased appears. While an LCD, piezo buzzer, load cell with its amplifier, RFID reader, microcontroller through its driver circuit, Bluetooth module, and other components are shown in Figure 16. A model of smart shopping trolley can be shown in Figure 17.

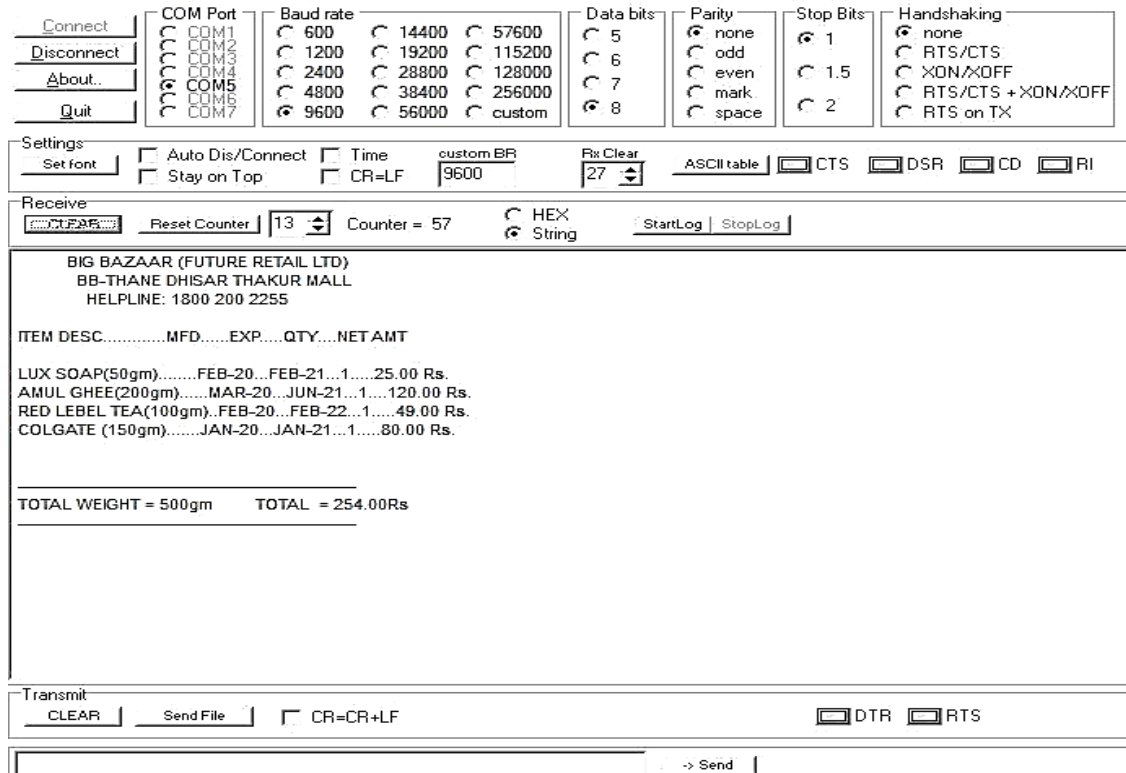

Figure 15. Purchase output at the end

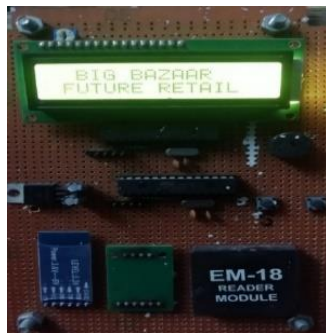

Figure 16. Circuit of the smart trolley



Figure 17. Smart shopping trolley model

5. CONCLUSION

The development of science and technology is ongoing so that modern gadgets and technologies are being created and produced. By saving them time, this technique is employed at shopping malls to assist customers in making purchases. In this paper, RFID is utilized as a safety admittance for the item, it improves the effectiveness of surveillance. This project starts an automated central billing arrangement in malls and supermarkets. Customers no longer need to stand in line at counters to pay their bills because their purchase information is transferred to the central billing unit. This makes the charging process far quicker and simpler. Along with these features, the technique makes sure that instances of theft brought on by dishonest customers are identified, which increases the system's credibility and attraction to both customers and businesses. As a consequence, the purchasing experience will be improved significantly.



Numerous details, including item cost, expiration date, and other information are continually shown on the LCD affixed to the cart. Therefore, we anticipate that automatic product billing employing RFID technology will increase in popularity over the next several years, making processes more efficient and systematic. The created prototype model successfully accomplishes the desired result. The created device is inexpensive, simple to use, and doesn't require any specialized training. Making a decision may be done in the

cart itself, which can be used at shopping malls for a quick and efficient manner to buy items that will save customers' energy, time, and money. The paper is evaluated using a variety of trial scenarios, with various factors being considered for each of the actual trials. Only things that are water sensitive can be carried on the cart since the tags used in this project are water sensitive. In order to prevent non-detection, tags are affixed to objects in a circular pattern because the tags used in this paper can only detect one side. If it can employ stronger tags which are now the subject of research, we can resolve this issue.



REFERENCES

- [1] U. Gangwal, S. Roy, and J. Bapat, "Smart shopping cart for automated billing purpose using wireless sensor networks," in *The Seventh International Conference on Sensor Technologies and Applications*, 2013, pp. 1–5.
- [2] N. Đurđević, A. Labus, D. Barać, M. Radenković, and M. D. -Zrakić, "An approach to assessing shopper acceptance of beacon triggered promotions in smart retail," *Sustainability*, vol. 14, no. 6, pp. 1–25, 2022, doi: 10.3390/su14063256.
- [3] J. Suryaprasad, B. O. P. Kumar, D. Roopa, and A. K. Arjun, "A novel low-cost intelligent shopping cart," in *2011 IEEE 2nd International Conference on Networked Embedded Systems for Enterprise Applications*, 2011, pp. 1–4, doi: 10.1109/NESEA.2011.6144946.
- [4] P. Castillejo, J. -F. Martinez, J. R. -Molina, and A. Cuerva, "Integration of wearable devices in a wireless sensor network for an E-health application," *IEEE Wireless Communications*, vol. 20, no. 4, pp. 38–49, 2013, doi: 10.1109/MWC.2013.6590049.
- [5] A. Karmouche and Y. S. -Alj, "Aisle-level scanning for pervasive RFID-based shopping applications," in *2012 International Conference on Computer Systems and Industrial Informatics*, 2012, pp. 1–4, doi: 10.1109/ICCSII.2012.6454582.
- [6] M. Ghazal *et al.*, "AI-powered service robotics for independent shopping experiences by elderly and disabled people," *Applied Sciences*, vol. 11, no. 19, pp. 1–27, 2021, doi: 10.3390/app11199007.
- [7] N. Mitton, S. Papavassiliou, A. Puliafito, and K. S. Trivedi, "Combining Cloud and sensors in a smart city environment," *EURASIP Journal on Wireless Communications and Networking*, vol. 2012, no. 1, pp. 1–10, 2012, doi: 10.1186/1687-1499-2012-247.
- [8] M. K. Abed, M. M. Kareem, R. K. Ibrahim, M. M. Hashim, S. Kurnaz, and A. H. Ali, "Secure medical image steganography method based on pixels variance value and eight neighbors," in *2021 International Conference on Advanced Computer Applications (ACA)*, 2021, pp. 199–205, doi: 10.1109/ACA52198.2021.9626807.
- [9] K. G. Devi, T. A. Kaarthik, N. K. Selvi, K. Nandhini, and S. Priya, "Smart shopping trolley using RFID based on IoT," *International Journal of Innovative Research in Computer and Communication Engineering*, vol. 5, no. 3, pp. 5392–5398, 2017, doi: 10.15680/IJIRCC.2017.0503.
- [10] S. K. Shankar, S. Balasubramani, S. A. Basha, S. Ariz Ahamed and N. S. Kumar Reddy, "Smart Trolley for Smart Shopping with an Advance Billing System using IoT," *2021 5th International Conference on Computing Methodologies and Communication (ICCMC)*, Erode, India, 2021, pp. 390-394, doi: 10.1109/ICCMC51019.2021.9418348.
- [11] S. Kamble, S. Meshram, R. Thokal, and R. Gakre, "Developing a multitasking shopping trolley based on RFID technology," *International Journal of Soft Computing and Engineering (IJSCE)*, vol. 3, no. 6, pp. 179–183, 2014.
- [12] A. H. Ali, A. D. Farhood, and M. K. Naji, "Analysis of a framework implementation of the transceiver performances for integrating optical technologies and wireless LAN based on OFDM-RoF," *International Journal of Electrical and Computer Engineering (IJECE)*, vol. 10, no. 4, pp. 4252–4260, 2020, doi: 10.11591/ijece.v10i4.pp4252-4260.
- [13] P. Chandrasekar and T. Sangeetha, "Smart shopping cart with automatic billing system through RFID and ZigBee," in *International Conference on Information Communication and Embedded Systems (ICICES2014)*, 2014, pp. 1–4, doi: 10.1109/ICICES.2014.7033996.
- [14] T. Sarala, Y. A. Sudha, K. V. Sindhu, C. Suryakiran and B. N. Nithin, "Smart Electronic Trolley for Shopping Mall," *2018 3rd IEEE International Conference on Recent Trends in Electronics, Information & Communication Technology (RTEICT)*, Bangalore, India, 2018, pp. 2422-2427, doi: 10.1109/RTEICT42901.2018.9012466.
- [15] T. Song, R. Li, B. Mei, J. Yu, X. Xing, and X. Cheng, "A privacy preserving communication protocol for IoT applications in smart homes," *IEEE Internet of Things Journal*, vol. 4, no. 6, pp. 1844–1852, 2017, doi: 10.1109/IJOT.2017.2707489.
- [16] M. A. Sarwar, Y.-A. Daraghmi, K.-W. Liu, H.-C. Chi, T.-U. Ik, and Y.-L. Li, "Smart shopping carts based on mobile computing and deep learning cloud services," in *2020 IEEE Wireless Communications and Networking Conference (WCNC)*, 2020, pp. 1–6, doi: 10.1109/WCNC45663.2020.9120574.
- [17] S. A. S. Lafta, M. M. Abdulkareem, R. K. Ibrahim, M. M. Kareem, and A. H. Ali, "Quality of service performances of video and voice transmission in universal mobile telecommunications system network based on OPNET," *Bulletin of Electrical Engineering and Informatics*, vol. 10, no. 6, pp. 3202–3210, 2021, doi: 10.11591/eei.v10i6.3139.
- [18] R. Li, T. Song, N. Capurso, J. Yu, J. Couture, and X. Cheng, "IoT applications on secure smart shopping system," *IEEE Internet of Things Journal*, vol. 4, no. 6, pp. 1945–1954, 2017, doi: 10.1109/IJOT.2017.2706698.
- [19] Z. Ali and R. Sonkusare, "RFID based smart shopping and billing," *International Journal of Advanced Research in Computer and Communication Engineering*, vol. 2, no. 12, pp. 4696–4699, 2013.
- [20] M. M. Kareem, S. A. S. Lafta, H. F. Hashim, R. K. A. -Azzawi, and A. H. Ali, "Analyzing the BER and optical fiber length performances in OFDM RoF links," *Indonesian Journal of Electrical Engineering and Computer Science*, vol. 23, no. 3, pp. 1501–1509, 2021, doi: 10.11591/ijeecs.v23.i3.pp1501-1509.
- [21] M. R. Sawant, K. Krishnan, S. Bhokre, and P. Boshale, "The RFID based smart shopping cart," *International Journal of Engineering Research and General Science*, vol. 3, no. 2, pp. 275–280, 2015.
- [22] T. Hanooja, C. G. Raji, M. Sreelekha, J. Koniya, V. Muhammed Ameen and M. Mohammed Noufal, "Human Friendly Smart Trolley with Automatic Billing System," *2020 4th International Conference on Electronics, Communication and Aerospace Technology (ICECA)*, Coimbatore, India, 2020, pp. 1614-1619, doi: 10.1109/ICECA49313.2020.9297439.
- [23] K. Guo, M. Yang, and Y. Zhang, "Computation offloading over a shared communication channel for mobile cloud computing," in *2018 IEEE Wireless Communications and Networking Conference (WCNC)*, 2018, pp. 1–6, doi: 10.1109/WCNC.2018.8376951.
- [24] M. K. Dev, R. Kannan, M. Agarshan, S. Karthik and K. Lakshmi, "Automated Billing Smart Trolley and Stock Monitoring," *2021 5th International Conference on Computing Methodologies and Communication (ICCMC)*, Erode, India, 2021, pp. 500-505, doi: 10.1109/ICCMC51019.2021.9418043.
- [25] H. F. Hashim, M. M. Kareem, W. K. Al-Azzawi, and A. H. Ali, "Improving the performance of photovoltaic module during partial shading using ANN," *International Journal of Power Electronics and Drive Systems (IJPEDS)*, vol. 12, no. 4, pp. 2435–2442, 2021, doi: 10.11591/ijped.v12.i4.pp2435-2442.



BIOGRAPHIES OF AUTHORS

Maham Kamil Najji    received her B.Eng. and M.Sc. degrees in Electronic and Communication Engineering from the University of Technology Baghdad 2003 and Sam Higginbottom, India, 2014 respectively. She is currently an academic staff member in the Department of Electronics Techniques Engineering, Institute of Technology, Baghdad, Iraq. Her research interests are artificial intelligent, IoT, microcontrollers, and communication. She can be contacted at email: Maham.kamel@mtu.edu.iq.





Alaa Desher Farhood    is received his B.Eng. and M.Sc. degrees in Electronic and Communication Engineering from the University of Technology Baghdad 1998 and Sam Higginbottom, India, 2014 respectively. He is currently an academic staff member in the Department of Electrical Techniques Engineering at Technical Instructor Training Institute, Middle Technical University, Baghdad, Iraq. His research interests are artificial intelligent, IoT, image processing, microcontrollers, FPGA, and wireless communications. He can be contacted at email: alaa.desher@gmail.com and Alaa.desher@mtu.edu.iq.

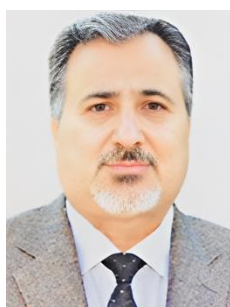

Hayder Fadhil Fahad    is received his B.Eng. and M.Sc. degrees in Electronic and Communication Engineering from the University of Almustansiria Baghdad in 2011 and 2021 respectively. He is currently an academic staff member in the Department of Electrical Techniques Engineering at Technical Instructor Training Institute, Middle Technical University, Baghdad, Iraq. His research interests are artificial intelligent, IoT, microcontrollers, and wireless communications. He can be contacted at email: hayder.fadhil.fahad@mtu.edu.iq.



Adnan Hussein Ali    is professor at the Middle Technical University, Baghdad, Iraq, where he has been a faculty member since 2007. His graduated with a B.Sc. degree in Electronic Engineering from University of Technology, Baghdad, Iraq, in 1987, M.Sc. in Electronic and Communication Technology from University of Technology, Baghdad in 1999, and Ph.D. from Department of Laser and Optoelectronics, University of Technology, Baghdad in 2007. His research interests in the area of optical communication, cloud computing, RoF, WSN, and PV. He is the author/co-author of over 60 research publications. He can be contacted at email: dr.adnan@mtu.edu.iq, aaddnnaann63@gmail.com.